

SSB161L

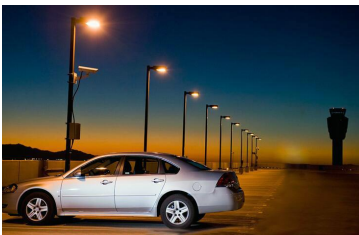

APPLICATIONS:

- Parking Lot
- Shopping centers
- Residential areas
- All Area/Flood Applications



Project:

Type:

Prepared By:

Date:

FEATURES

- Surface oxidation of aluminum profile, high Pressure Die Cast, Powder Coated Aluminum driver box
- Polycarbonate optical lens :Type III medium
- Slip Fitter standard, Mounting Arms or swivel pendant for optional
- Long-life, high-efficiency surface mounting LEDs
- Integrated Motion Sensor for optional
- L70>50,000 Hours Rated Lifespan
- 5-year Warranty
- Ambient Temperature -35 to 40 °C
- Fixture Protection Class IP65
- ETL Wet Location Listed

LED/DRIVER

- Universal Input Voltage 120-277Vac 50/60 Hz
- Optional Input Voltage 249-528Vac 50/60 Hz
- Line to Earth 10KV Surge Protection
- IP67 Rated LED Driver
- Power Factor > 0.90
- THD < 20%
- CRI > 70
- CCT : 4000K/5000K

ITEM NO	Input Wattage	Input Voltage	LED Module	Delivered Lumens	Luminaire Efficacy	COLOR TEMP(CCT)
SSB161L	250W	120-277V	4	33750 LM	135 LM/W	5000 K
SSB161L	200W	120-277V	4	29000 LM	145 LM/W	5000 K
SSB161L	150W	120-277V	3	21750 LM	145 LM/W	5000 K
SSB161L	100W	120-277V	2	14500 LM	145 LM/W	5000 K

DIMENSIONS

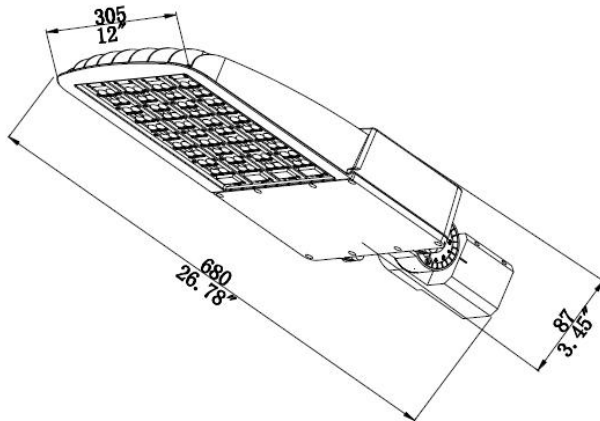



100W\150W\200W\250W

PHOTOMETRICS

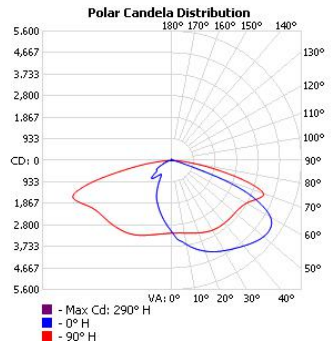
TYPE III

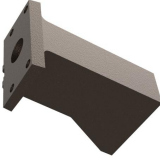

PART

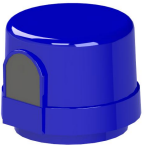
Slip Fitter	6" Kitty Hawk Arm	Swivel Bracket	Photocontrol
			

SHIPPING DATA

Package:63*35*15 CM

Approximate Net Weight:

8.3KG@SSB161L250W

8.3KG@SSB161L200W

7.9KG@SSB161L150W

7.8KG@SSB161L100W

ORDERING CODES

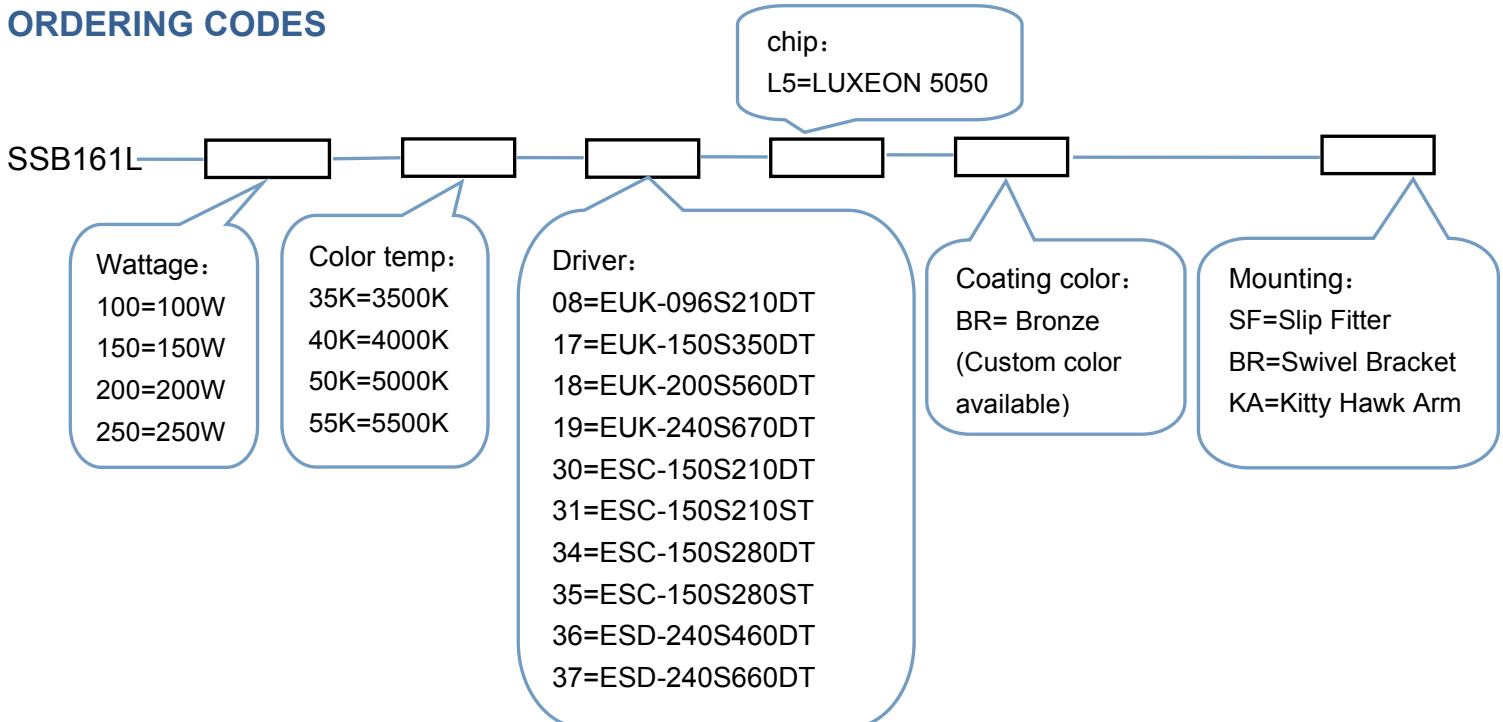

Typical Order Example:SSB161L-250-50K-SF-T3-DB