

SSL2L/4L/8L



APPLICATIONS:

- Supermarket
- Offices
- Conference/Meeting Rooms



Project:

Type:

Prepared By:

Date:

FEATURES

- Extruded aluminum housing with smooth finish, Anodized surface
- Standard durable and Low-gloss frosted acrylic lens
- 3/8" Rod Pendant mount , Horizontal Wall Mount Or Surface
- Long-life, high-efficiency surface mounting LEDs
- Integrated Motion Sensor for optional
- Integrated Emergency Battery for optional
- L70>50,000 Hours Rated Lifespan
- 5-year Warranty
- Ambient Temperature -35 to 40 °C
- ETL Dry Location Listed

LED/DRIVER

- Universal Input Voltage 120-277Vac 50/60 Hz
- Optional Input Voltage 249-528Vac 50/60 Hz
- Line to Earth 6KV Surge Protection
- Power Factor > 0.90
- THD < 20%
- CRI > 80
- CCT : 4000K/5000K

ITEM NO	Input Wattage	Input Voltage	LED Module	Delivered Lumens	Luminaire Efficacy	COLOR TEMP(CCT)
SSL8L75	75W	120-277V	4	8250 LM	110 LM/W	5000 K
SSL4L50	50W	120-277V	2	5500 LM	110 LM/W	5000 K
SSL4L38	38W	120-277V	2	4180 LM	110 LM/W	5000 K
SSL2L25	25W	120-277V	2	2750 LM	110 LM/W	5000 K

DIMENSIONS

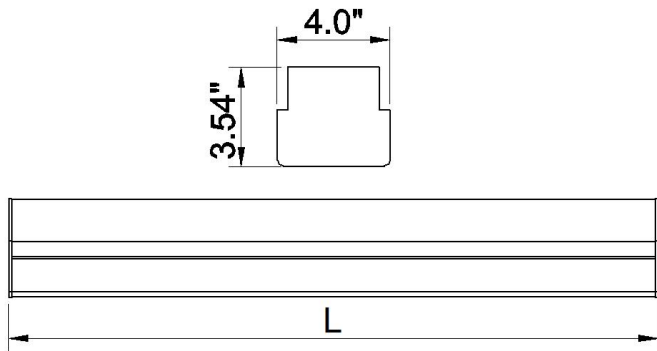

PHOTOMETRICS

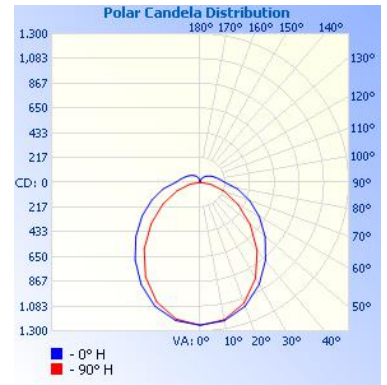

SSL2L:L=24"

SSL4L:L=48"

SSL8L:L=96"

Part

None

SHIPPING DATA

Package: 126*24*22 CM @ SSL4L

Approximate Net Weight: 10.8 KG @ SSL4L

ORDERING CODES

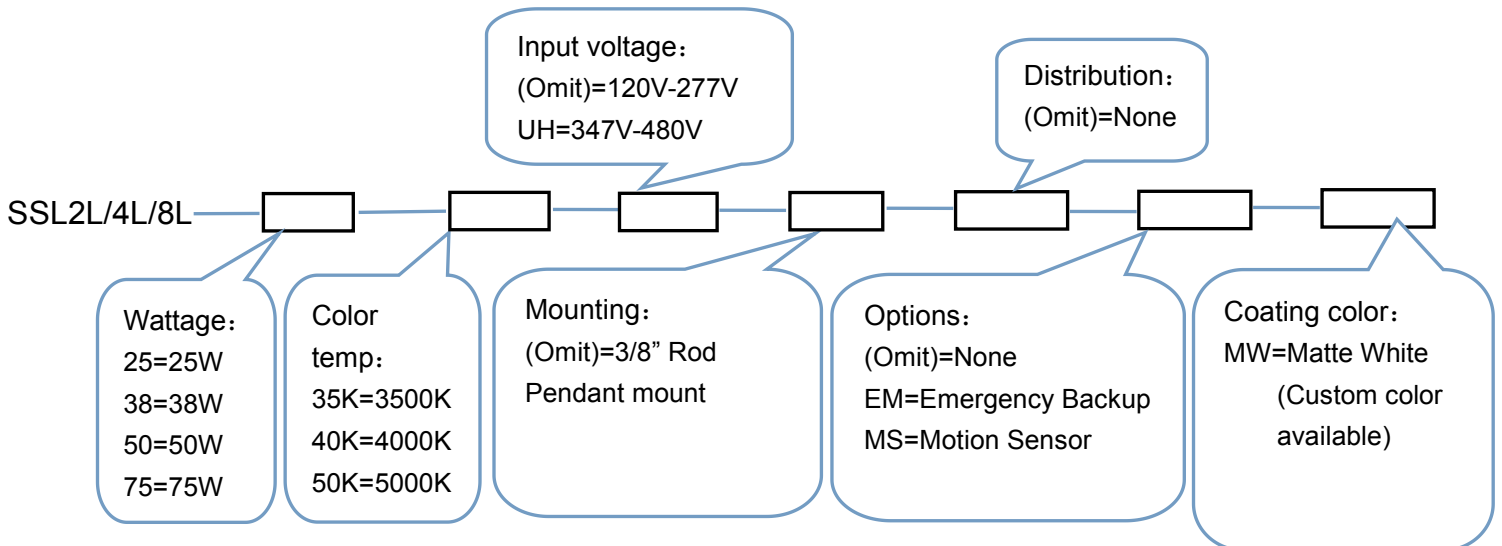

Typical Order Example: SSL4L-50-50K-MW