

### SWP211L



Project:

Type:

Prepared By:

Date:

### FEATURES

- High Pressure Die Cast, Powder Coated Aluminum Housing
- Aluminum reflector
- Prismatic borosilicate glass lens
- Recessed outlet box or directly to wall,
- Quick-mounting bracket available
- Long-life, high-efficiency surface mounting LEDs
- L70>50,000 Hours Rated Lifespan
- 5-year Warranty
- Ambient Temperature -35 to 40 °C
- IP67 Rated LED Module
- ETL Wet Location Listed

### APPLICATIONS:

- Walkway
- Perimeter Lighting
- Commercial Buildings
- Railway Platform



### LED/DRIVER

- Universal Input Voltage 120-277Vac 50/60Hz
- Optional Input Voltage 249-528Vac 50/60Hz
- Line to Earth 6KV Surge Protection
- IP67 Rated LED Driver
- Power Factor > 0.90
- THD < 20%
- CRI > 70
- CCT : 4000K/5000K

ITEM NO	Input Wattage	Input Voltage	LED Module	Delivered Lumens	Luminaire Efficacy	COLOR TEMP(CCT)
SWP211L38	38W	120-277V	1	3648 LM	96 LM/W	5000 K

### DIMENSIONS

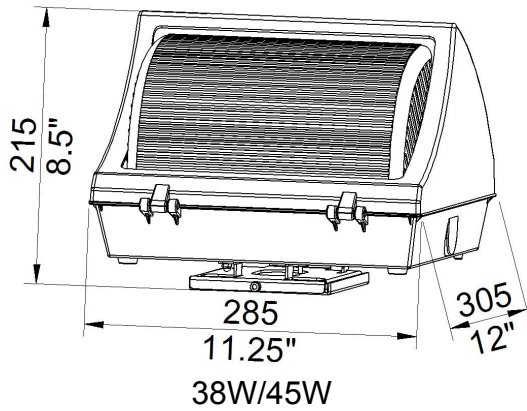

### PHOTOMETRICS

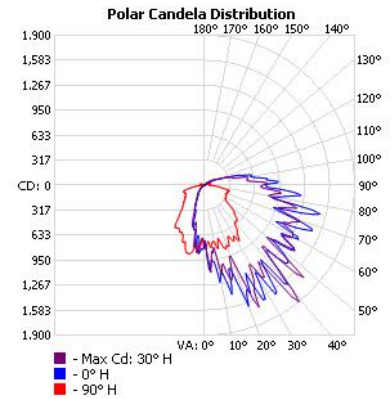

### PARTS

Quick-mounting Bracket



### SHIPPING DATA

Package: 36\*33.5\*26.5 CM

Approximate Net Weight: 4.2 KG

### ORDERING CODES

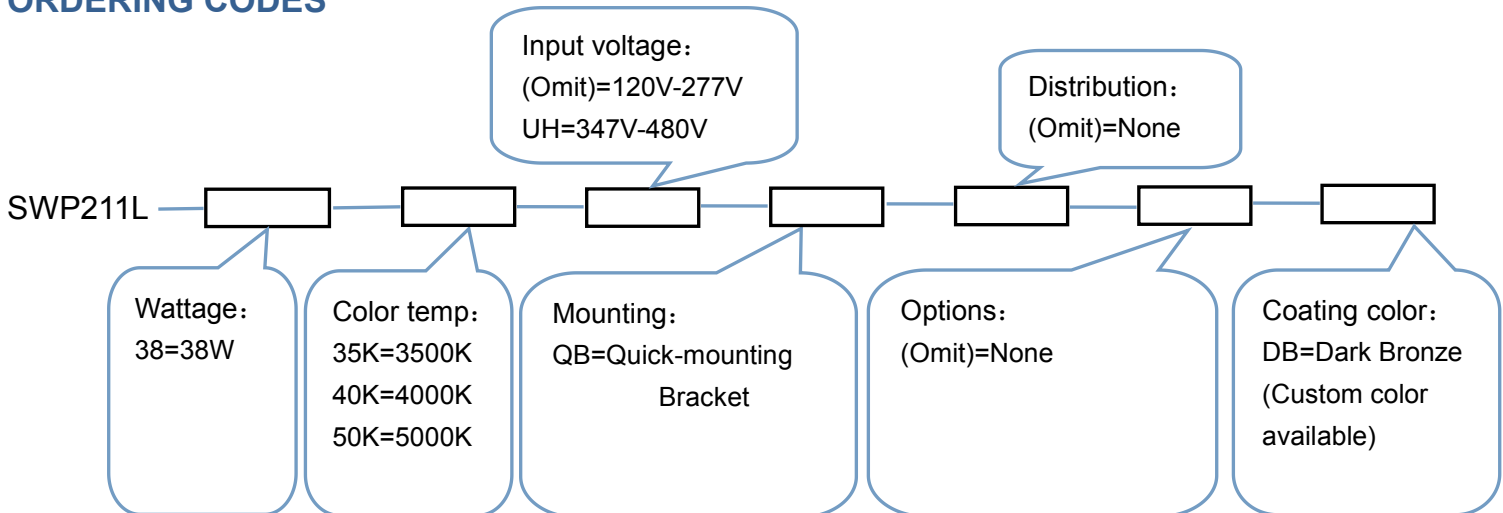

Typical Order Example: SWP211L-38-50K-QB-DB