

SHB306L



Project:

Type:

Prepared By:

Date:

FEATURES

- Combination of steel and aluminum housing
- MCPET reflector standard, Aluminum reflector for optional
- Clear PC Lens Standard, Frosted PC Lens for optional
- 120°X90° distribution standard, 120°X60° for optional
- 3/4" Pendant, hook or Chain/Cable Mount for optional
- Motion Sensor for optional
- Long-life, high-efficiency surface mounting LEDs
- L70>50,000 Hours Rated Lifespan
- 5-year Warranty
- Ambient Temperature -35 to 40 °C
- ETL Dry Location Listed

APPLICATIONS:

- Shopping Centers
- Residential Areas
- Factory
- Airports



LED/DRIVER

- Universal Input Voltage 120-277Vac 50/60 Hz
- Optional Input Voltage 249-528Vac 50/60 Hz
- Line to Earth 10KV Surge Protection
- IP67 Rated LED Driver
- Power Factor > 0.90
- THD < 20%
- CRI > 70
- CCT : 4000K/5000K

ITEM NO	Input Wattage	Input Voltage	LED Module	Delivered Lumens	Luminaire Efficacy	COLOR TEMP(CCT)	Lens
SHB306L460	460W	120-277V	1	64400 LM	140	5000 K	Clear
SHB306L380	380W	120-277V	1	53200 LM	140	5000 K	Clear
SHB306L300	300W	120-277V	1	42000 LM	140	5000 K	Clear

DIMENSIONS

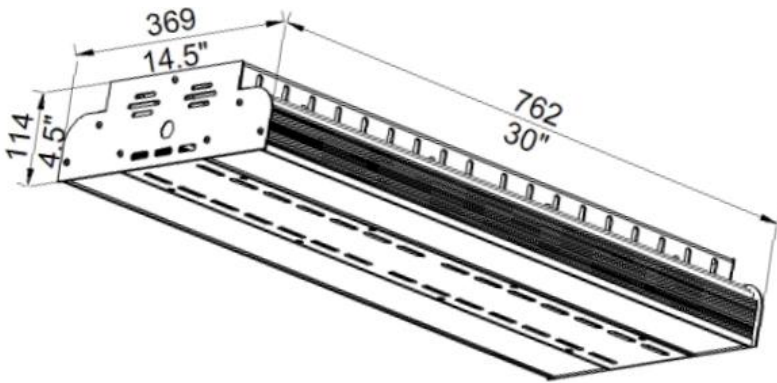

300W,380W,460W

PHOTOMETRICS

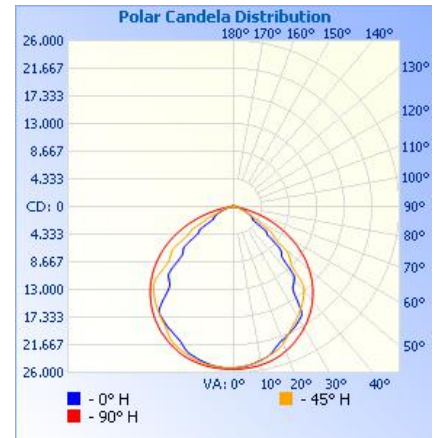

MOUNT WAY

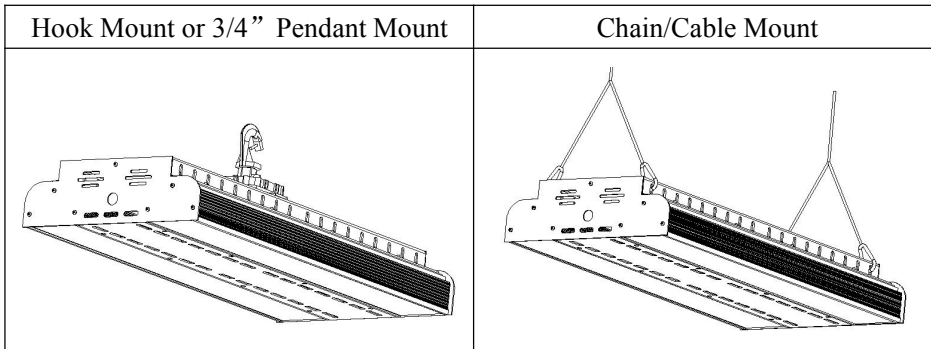

SHIPPING DATA

Package: 82.5X42X16.5 CM

Approximate Net Weight:15.7 KG

ORDERING CODES

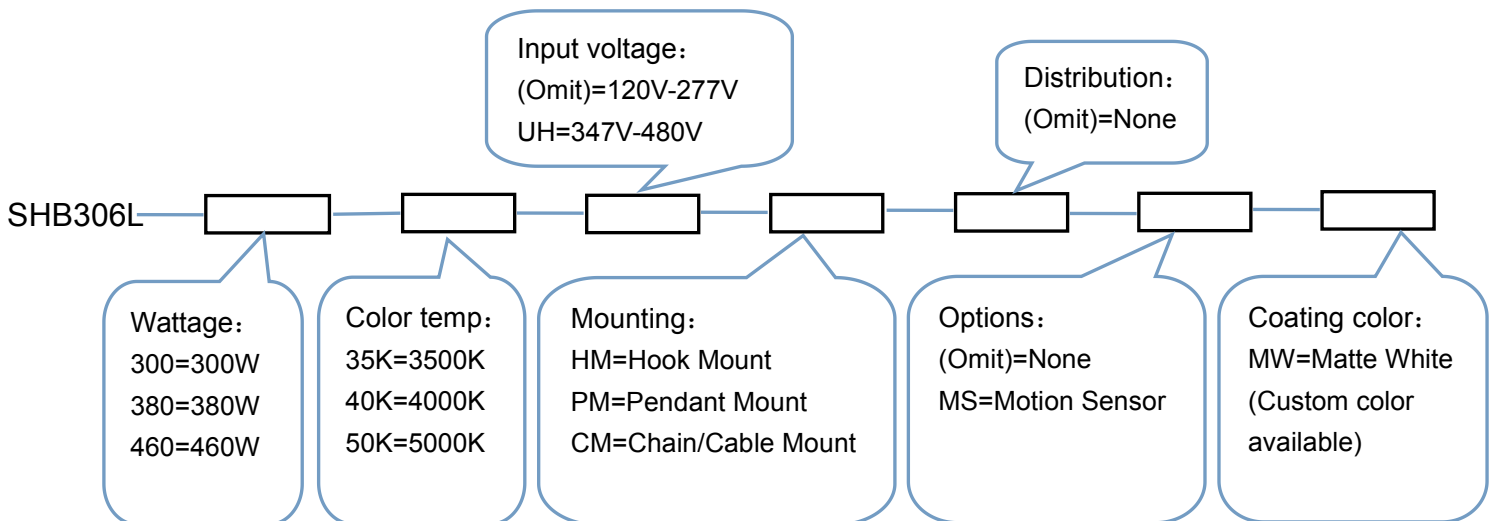

Typical Order Example:SHB306L-460-50K-HM-MW