

SSP602L



Project:

Type:

Prepared By:

Date:

FEATURES

- High Pressure Die Cast, Powder Coated Aluminum Housing
- Polycarbonate optical lens : 15° Flood optic ,40° Flood optic
110° Flood optic, Type V
- Yoke Mount standard, U Bracket for optional
- Light shield for optional
- lightning protector for optional
- Long-life, high-efficiency surface mounting LEDs
- L70>50,000 Hours Rated Lifespan
- 5-year Warranty
- Ambient Temperature -35 to 40 °C
- Fixture Protection Class IP66
- ETL Wet Location Listed

APPLICATIONS:

- Field Houses
- Airport
- Indoor Stadiums



LED/DRIVER

- Universal Input Voltage 120-277Vac 50/60 Hz
- Optional Input Voltage 249-528Vac 50/60 Hz
- Line to Earth 6KV Surge Protection
- IP67 Rated LED Driver
- Power Factor > 0.90
- THD < 20%
- CRI > 70
- CCT : 4000K/5000K

ITEM NO	Input Wattage	Input Voltage	LED Module	Delivered Lumens	Luminaire Efficacy	COLOR TEMP(CCT)
SSP602L650	650W	120-277V	1	81250 LM	125 LM/W	5000 K

DIMENSIONS

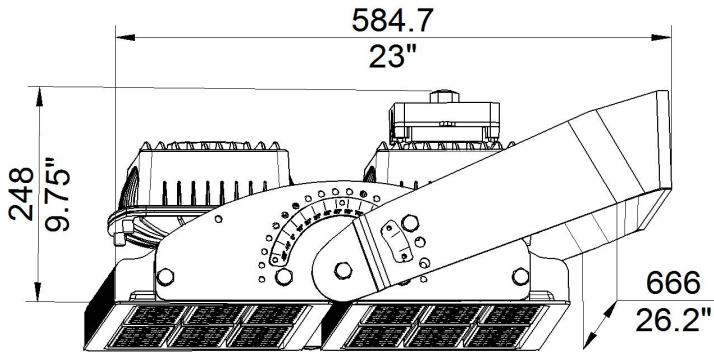

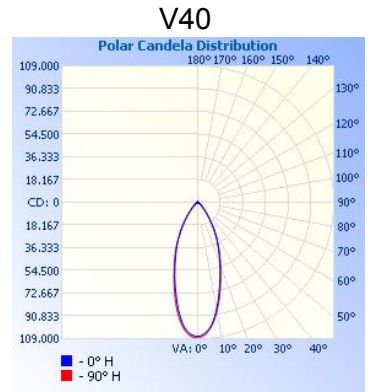

650W

PHOTOMETRICS

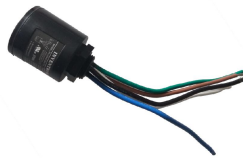

PARTS

Yoke Mount	U Bracket	Light Shield	Lightning Protector
			

SHIPPING DATA

Package: 72*61.5*28 CM

Approximate Net Weight: 37 KG

ORDERING CODES

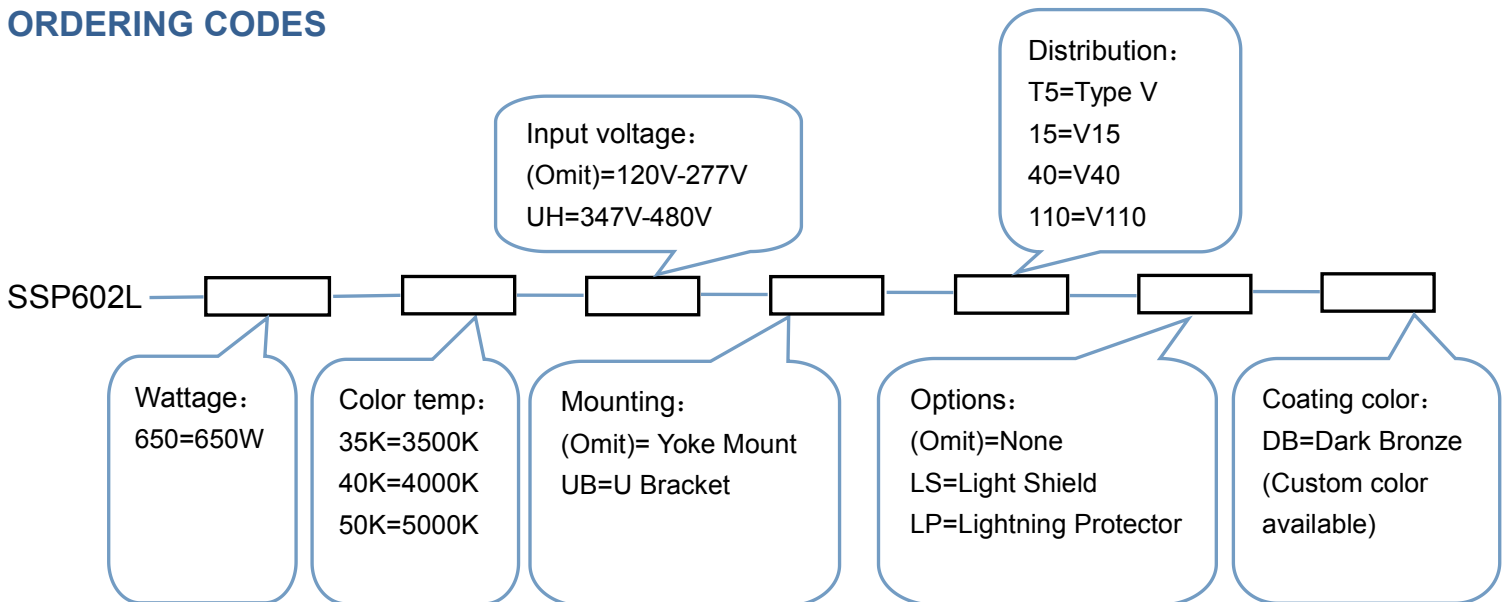

Typical Order Example: SSP602L-650-50K-40-DB